

AUTOMATIC DOUBLE SIDE LABELING MACHINE

雙面式自動貼標機



ISO 9001 : 2008



039

0 1 5 9 9 0

MODEL :

CJL-3000A

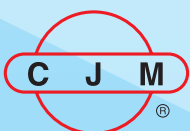

CHYUN JYE

群捷機械有限公司

CHYUN JYE MACHINERY CO., LTD.

公司：桃園縣龜山鄉龍壽村龍校街121巷2弄4號

E-mail: chyunjye@ms15.hinet.net

<http://www.chyunjye.com>

FACTORY : 1F, NO. 4, ALLEY 2, LANE 121, LUNG

HSIAO STREET, LUNG-SHOU VILLAGE KUEI SHAN

HSIANG, TAO YUAN HSIEN, TAIWAN, R.O.C.

TEL : 886-3-320-5757

FAX : 886-3-3295378

雙面式自動貼標機

AUTOMATIC DOUBLE SIDE LABELING MACHINE

CJL-3000A

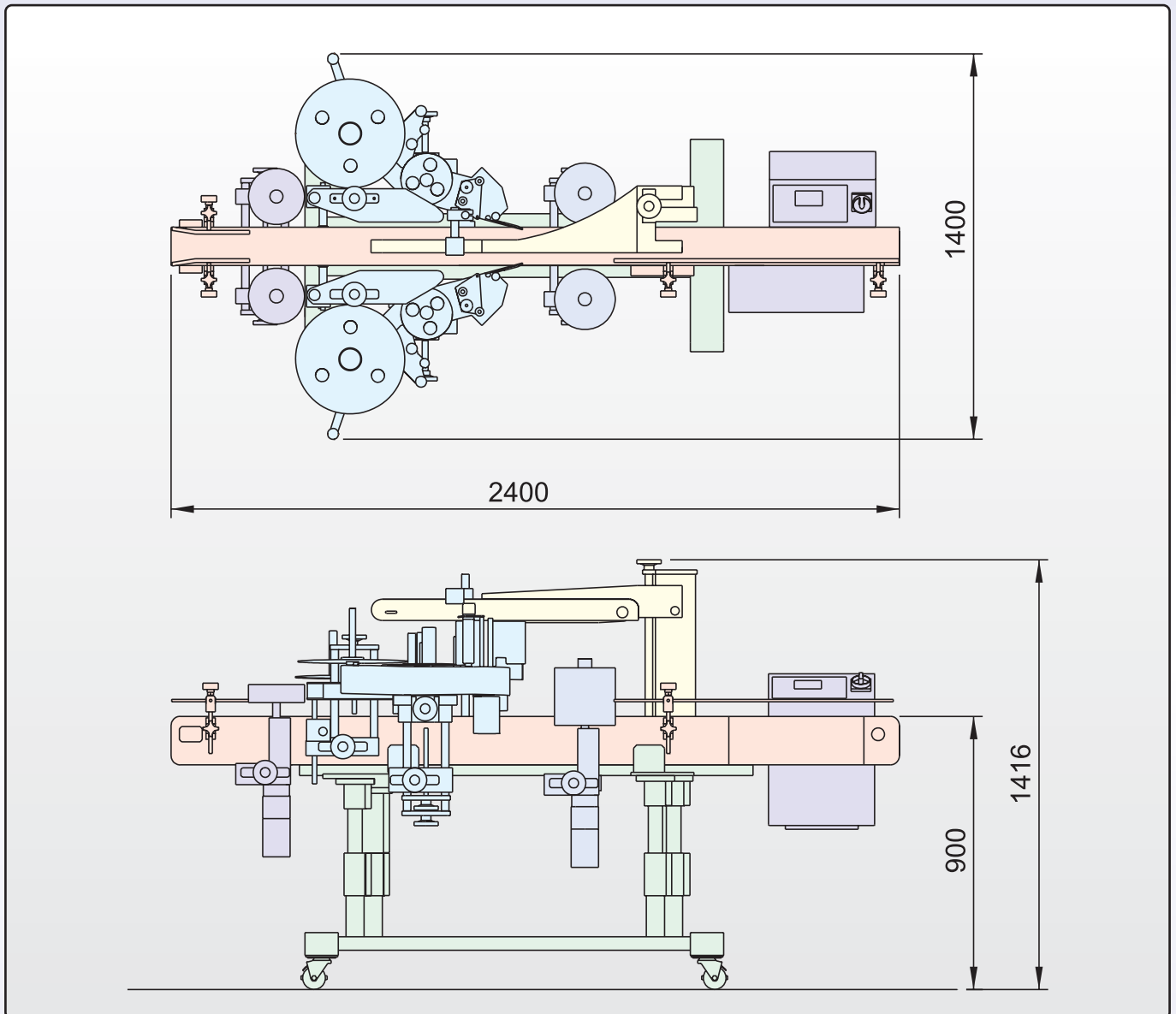

特性：

- 本機適用於扁平、方形或不規則之容器，同時貼附前後兩張標籤，並可選擇單面貼或雙面貼均可。
- 依產品需要可加裝打印機。

Feature:

1. Suitable for flat, square or irregular shape containers labeling.
2. For adhere two labels to the containers simultaneously either on one side or both sides.
3. Optional device: lot number printer.

Specificaitons 詳細規格

型號 Model	CJL-3000A	CJL-3000B
機器尺寸 Machine Size(LxWxH)	2500x1450x1400	2500x1450x1400
貼標速度 Labeling Speed	10-200 label/min.	10-200 label/min.
標籤長度 Label length	10-340mm	10-340mm
標籤高度 Label height	20-135mm	20-200mm
貼標物高度 Product Height	40-320	40-320
貼標物厚度(直徑)Product Thickness (Diameter)	30-120	30-120
紙卷內徑/外徑 Label Reel (ID)/(OD)	76m/m / 360 m/m	
電壓 Power Supply	110/220V 50/60HZ Voltage is one-way	

Specificaitons are subject to change without notice. 規格若有變更恕不另行通知。